

Vanguard® Medium FTS 370w LED

The Vanguard Medium FTS 370w is a white L-865 medium intensity LED obstruction lighting system for structures 200' and 700' AGL (FAA D-type towers). The system also meets FAA L-865 low intensity catenary requirements. It complies with CAR 621 2nd edition for medium intensity CL-865 flashing lights and ICAO 6th edition standards for medium intensity type A obstacle lights.

The FTS 370w uses a single cable for communications as well as beacon and marker power. Firmware can be upgraded for future compatibility with no need for controller modification. The single enclosure houses a low-voltage environment, removing the need for an interlock switch and allowing alarms to remain active when the door is open.

Standard Features

- Interleaved LEDs and by-pass circuitry provide longer life by allowing the loss of individual LEDs up to the 25% limit
- Surge immunity of 25kA to withstand 99% of all lighting strikes
- LTE modem for improved communication stability
- Ruggedized photodiode in metal housing with shielded cable
- Input power breaker switch eliminates replaceable fuses
- Outdoor Wi-Fi antenna for onsite diagnostics and lighting inspections
- Patented Fresnel optics to minimize ground scatter
- Aircraft Detection Lighting Systems (ADLS) interface
- Automatic failsafe switches to day mode after 19 hours of no mode change; can be disabled if necessary
- 4-line OLED backlit display for visibility in any lighting conditions
- Dry contact monitoring (day, night, marker, PED, GPS, comm alarms and mode status)
- Compliant with FAA AC 70/7460-1M and 1L
- 5-year warranty

System Options

- SMART card – monitor and control the system remotely, and receive full diagnostic information through LTE modem or ethernet-based connectivity. SNMP, Modbus or Eagle protocols may be used.
- GPS synchronization
- Upgrade firmware remotely
- TECK90 support – provides protection from RF interference and damage on high-power broadcast towers up to 700' AGL



FTS 370w

SPECIFICATIONS

Regulatory Compliance	FAA AC 150/5345-43J L-865, L-866
	FAA AC 70/7460-1M
	ICAO Annex 14 6th edition Medium Intensity type A
	Transport Canada CAR 621 2nd edition CL-865
	DGAC L-865
	CSA
	CE
Input Voltage	100-240 VAC ±48 VDC (optional)
Frequency	50-60 Hz
FH Dimensions	15.8 dia. x 7.3" (400 dia. x 190.5 mm)
FH Weight	26.3 lbs (11.92 kg)
FH Aerodynamic Wind Area	99.1 in ² (0.06 m ²)
Controller Dimensions	23 x 17.1 x 6.4" (584.2 x 434.3 x 162.6 mm)
Controller Weight	44 lbs (20 kg)
Protection Rating	IP66, NEMA 4X

POWER CONSUMPTION

		Wattage (IR)	Flash Rate	Flash Intensity *
L-865	Day (white)	80 W (70 W)	40 fpm	20,000 ±25%ECD
	Night (white)	40 W (40 W)	40 fpm	2,000 ±25%ECD
L-866	Day (white)	110 W (100 W)	60 fpm	20,000 ±25%ECD
	Night (white)	50 W (50 W)	60 fpm	2,000 ±25%ECD

* Optional 4,000 cd night mode for international standards.

FAA WHITE TOWER LIGHTING

FAA AC 70/7460-1M, 1L and 1K

- **Tower Type D1:** 200-350' including any appurtenances with 1 L-865 medium intensity beacon
- **Tower Type D2:** 350-700' including any appurtenances with 3 L-865 medium intensity beacons

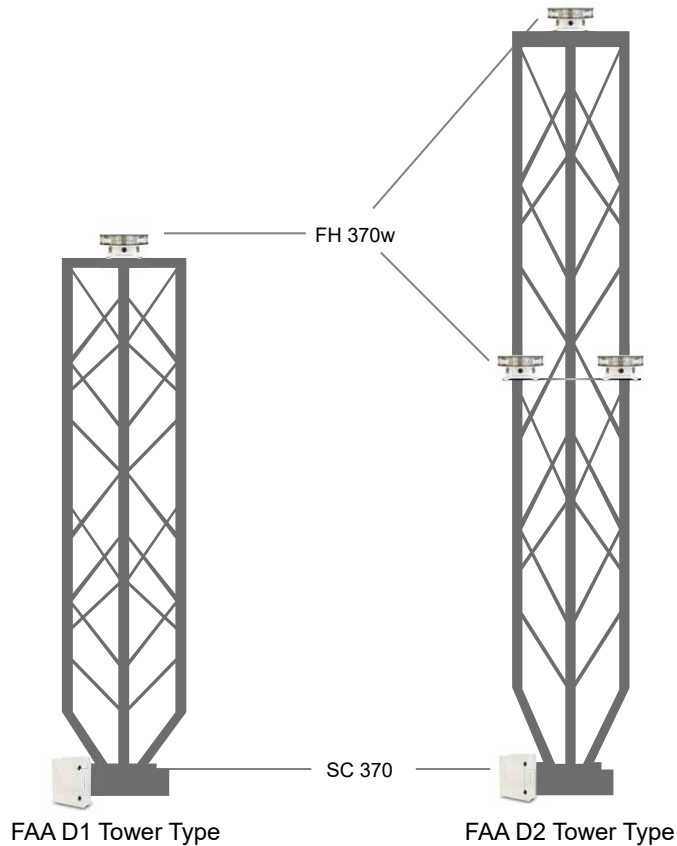

FLASH TECHNOLOGY

flashsales@spx.com | flashtechonology.com/obstruction | 1.615.503.2000

©2021 Flash Technology. All rights reserved. Data and specifications subject to change without notification. ISO 9001:2015. D370W-01 Rev F